

WHEN QUALITY COUNTS

HIGH QUALITY CONVEYING SYSTEMS
FOR AGRICULTURE AND INDUSTRY



**SKANDIA
ELEVATOR**

THE LEADING COMPANY

A MATTER OF EFFICIENCY AND PROFITABILITY



IT IS NO COINCIDENCE THAT SKANDIA ELEVATOR ARE THE INDUSTRY LEADER WHEN IT COMES TO CONVEYING SYSTEMS FOR AGRICULTURE AND INDUSTRY. OUR HIGH-QUALITY SYSTEMS ALLOW YOU TO GET AS MUCH AS POSSIBLE OUT OF YOUR PRODUCTION AND MAXIMISE PROFITABILITY. LET US EXPLAIN IN 7 STEPS WHY CHOOSING US AND OUR PRODUCTS IS A GOOD INVESTMENT.

1. DEPENDABILITY

Our conveying systems are reliable and dependable. There is no risk of costly stoppages halting production or harvesting.

Find out more on pages 4-5

2. SERVICE LIFE

The high quality guarantees a long service life. Our products go on working year after year and require a minimum of maintenance. Good for the environment, good for your wallet.

Find out more on pages 6-7

3. CUSTOMISATION

We have three product lines, all of which can be customised and integrated to suit your own specific needs. Every product line comes with several options for vertical, horizontal, inclined and curved transport. You need never pay for surplus performance to achieve the ideal system.

Find out more on pages 8-9

4. SAFETY

The safety inherent in the systems is the best available and ensures that transported materials are not mixed. The risk of personal injury is eliminated at the same time.

Find out more on pages 10-11

5. USER-FRIENDLY

Each and every function is designed with the user in mind – the self-regulating inlet and the fully automatic sweep conveyor, for example. Maximum capacity is always available to you, with no need for adjustments.

Find out more on pages 12-13

6. DELIVERY QUALITY

We work with high-tech robot technology and efficient pre-assembly of machine modules, resulting in unsurpassed fit, quality and delivery time. As a result, we are able to guarantee fast, reliable delivery even during peak season.

Find out more on pages 14-15

7. SECURITY

You can rely on us. We have 100 years of experience of the industry and manufacture more than 2000 machines each year, all of which are extremely reliable. Security and robustness are part of the very fabric of our company.

Find out more on pages 16-17

THE FIRST REASON TO CHOOSE SKANDIA ELEVATOR

DEPENDABILITY

Time is money. This holds true for agriculture just as it does for industry. Stoppages cause not only financial losses but also unnecessary stress.

But you can avoid stoppages by investing in high quality and smart design.

At Skandia Elevator, we design systems that are made for hard, intensive use. Our conveyors, elevators and accessories are able to withstand heavy loads from day one and for a long, long time to come. Our products are not the cheapest to purchase, but the most cost-effective as our well thought out designs and choices of materials make our products better and extend their service lives. The outstanding dependability of our systems has made us a leader in the industry. Precision permeates everything we do. Skandia Elevator holds accreditation to ISO 9001, which means that quality assurance is guaranteed at all stages. And this is something you will notice









THE SECOND REASON TO CHOOSE SKANDIA ELEVATOR

SERVICE LIFE

In this moment, conveyors and elevators from Skandia Elevator are in use all over the world.

Some machines have been in use for more than 30 years and are still in good condition.

This is the result of our materials selection and design. Galvanised steel can withstand all weathers, while overlapping seams and sealed joints keep wetness and dirt out. A complete system of machines from Skandia Elevator guarantees functionality from the very first day and throughout the entire service life of the facility. As well as offering financial benefits, this long service life is also positive for the environment. Less material and resources and less energy are used when every machine lasts longer. So a system from us is a sustainable investment.

THE THIRD REASON TO CHOOSE SKANDIA ELEVATOR

CUSTOMISATION

Requirements always vary. The things you need are dependent on your business area and the size of your production.

Skandia Elevator has three product lines: one for smaller facilities, one for large facilities, and one for facilities which operate daily. These systems can be integrated seamlessly with one another and expanded as your requirements change.

Every product line has a large number of different machines for vertical, horizontal, inclined and curved transport – this enables the design to be adapted to the specific requirements of your facility. As the Skandia Elevator range of products is made up of standardised machines in a flexible, modular system, all customisations are cost-effective. In other words, you will never have to pay for unnecessary functions – simply buy what you really need.









THE FOURTH REASON TO CHOOSE SKANDIA ELEVATOR

SAFETY

There is a major risk of accidentally mixing crops, but thanks to our smart design we have almost eliminated this risk completely.

Of course, there is nothing we can do about the human factor, but thanks to our technology the risk is reduced considerably. Another important aspect is the personal safety of yourself and your employees. Our systems are built to avoid hazardous work elements where people may be injured or become trapped.

THE FIFTH REASON TO CHOOSE SKANDIA ELEVATOR

USER-FRIENDLY

Each and every function and detail in our systems is designed to make users' lives easier. Things have to be straightforward and easy to work with.

The self-regulating inlet is one example of our user-friendliness. This means that the machine does not feed more than the specified capacity, regardless of crop. This takes place with absolutely no adjustments and helps us to achieve our unique dependability. It also reduces maintenance and servicing requirements.

Another example is our sweep conveyor, which empties silos fully automatically and with consistent results. Neither you nor your staff need to go into the silo to sweep the floor. This saves you time and helps you avoid risky work.









THE SIXTH REASON TO CHOOSE SKANDIA ELEVATOR

DELIVERY QUALITY

Working with us is simple and straightforward. We are quick to answer questions and offer consistently outstanding delivery reliability.

Our delivery times are short as we work with an optimised assembly flow and stock production, i.e. efficient production control. All our products are well packaged and labelled clearly when delivered so as to facilitate handling.

All our systems also come with clear, instructive assembly instructions so that the assembly process itself is quick and easy. The various components all fit together perfectly, so you can avoid hassle. We have a large stock of spare parts, so if you need us right in the middle of your hectic harvesting period or production phase, we will always deliver to you.

THE SEVENTH REASON TO CHOOSE SKANDIA ELEVATOR

SECURITY

Our company has existed for a long time, more than a century. This unique experience of the industry has given us unsurpassed knowhow.

At our plant, we have a world-class machine fleet that carries out highly automated punching, edging, assembly and joining to give you the best quality.

We manufacture more than 2000 machines a year and receive complaints about fewer than two per cent. Our outstanding level of quality can be explained primarily by the way in which we ourselves approach our work. We are never happy until everything is perfect and our customers have flawless systems. You can always rely on us.



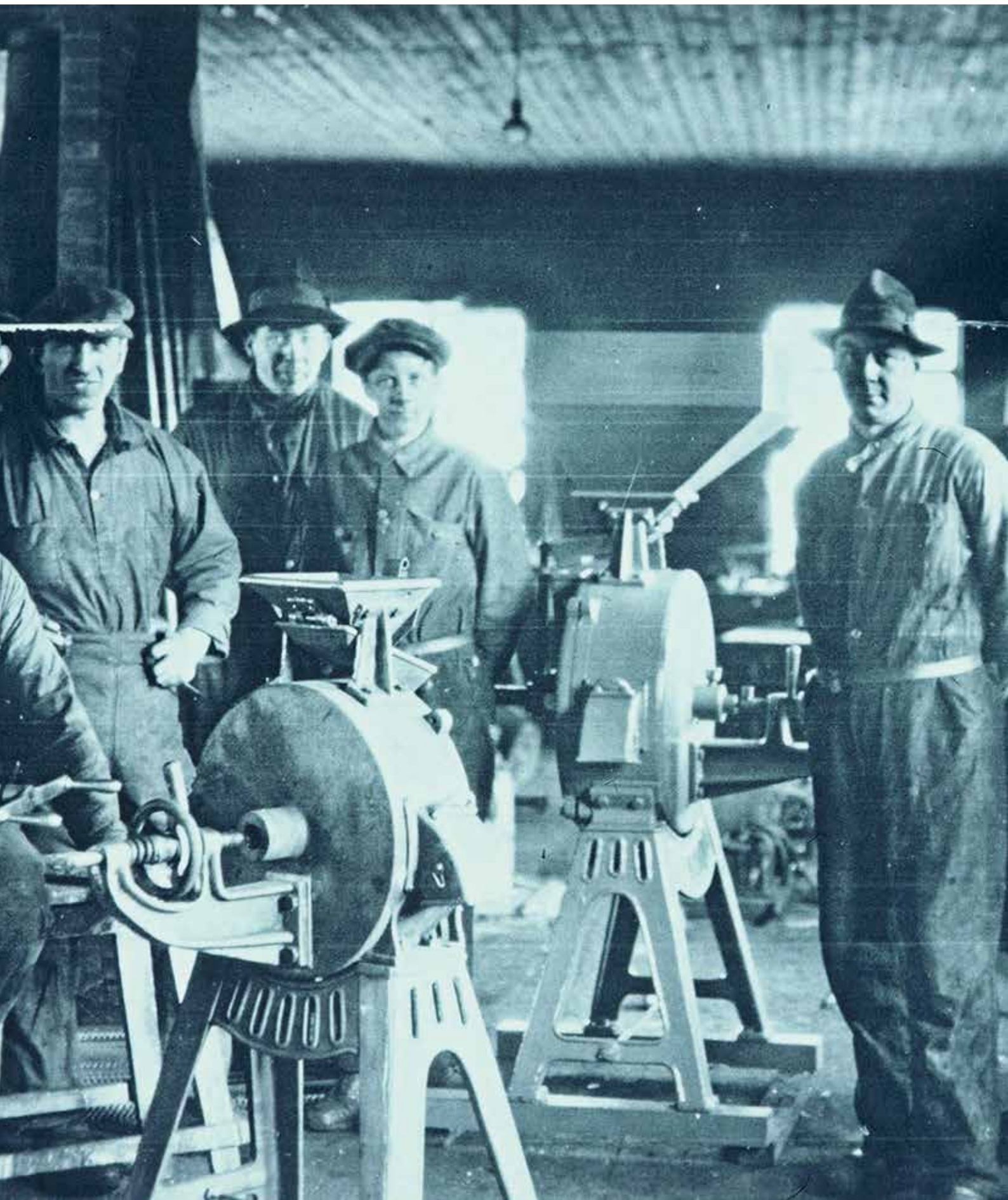

CONVEYING LINES TO MEET ALL NEEDS



SKANDIA ELEVATOR OFFERS AN IMPRESSIVE RANGE OF PRODUCTS, WITH CAPACITIES FROM **30 TONNES PER HOUR** UP TO **600 TONNES PER HOUR**. CONVEYING SOLUTIONS THAT ARE HORIZONTAL, VERTICAL, INCLINED AND CURVED ARE ALL AVAILABLE. AND OF COURSE, YOU CAN COMBINE THEM AS WELL.

L-LINE

Specially designed for smaller facilities and small and medium-sized farms in need of concentrated operation during the harvest period. *Find out more on page 21*

I-LINE

Our I-line products are designed for facilities running intensive operations all year round. Suitable for both medium-sized and large facilities. *Find out more on page 22*

H-LINE

H-line has been developed to meet the stringent demands of industry in particular. Suitable for large facilities operating every day, all year round. *Find out more on page 23*

ELEVATORS

All elevators from Skandia Elevator are made of galvanised steel and are compliant with the EU's Machinery Directive. They are designed to remain outdoors and withstand all kinds of weather conditions for many years. Besides grain, they can transport most dry granulated and pulverised materials.

CONVEYORS

Just like our elevators, all our conveyors are made of galvanised steel so that they can be used outdoors for a long time. They transport grain and most dry granulated and pulverised materials and are also available in models that are capable of working at slopes of 15°, 30° and 45°. Manufactured in accordance with the EU Machinery Directive.

OTHER EQUIPMENT

We also offer conveyor walks, dust and chaff extractors and ducting systems to facilitate work at your facility. Everything can be integrated with our elevators and conveyors and is made with the best possible quality.

PRODUCT LINE L-LINE

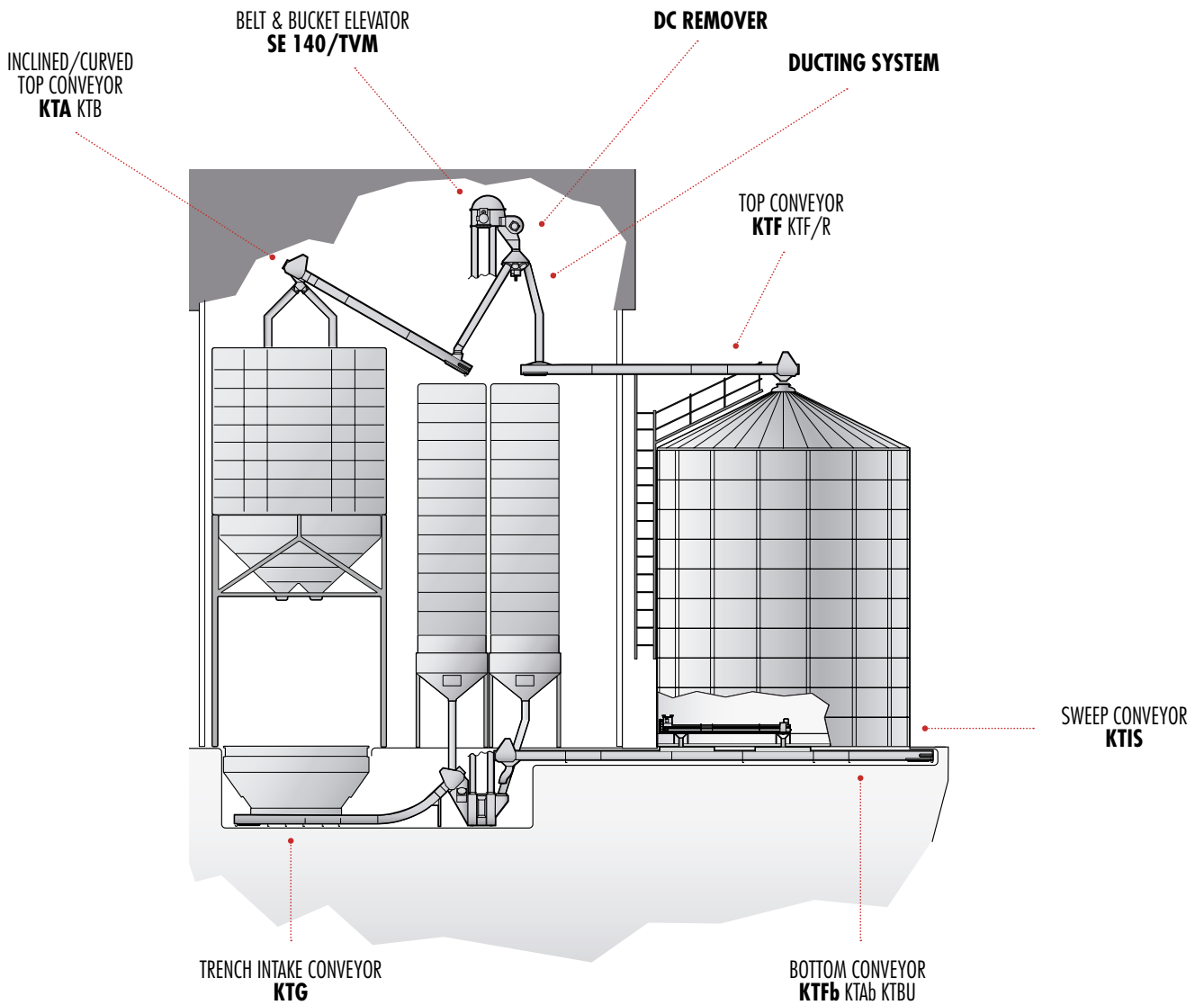

L-LINE

Specially designed for smaller facilities and small and medium-sized farms in need of concentrated operation during the harvest period.

CAPACITY



STORAGE SIZE



OPERATING TIME



PRODUCT LINE I-LINE

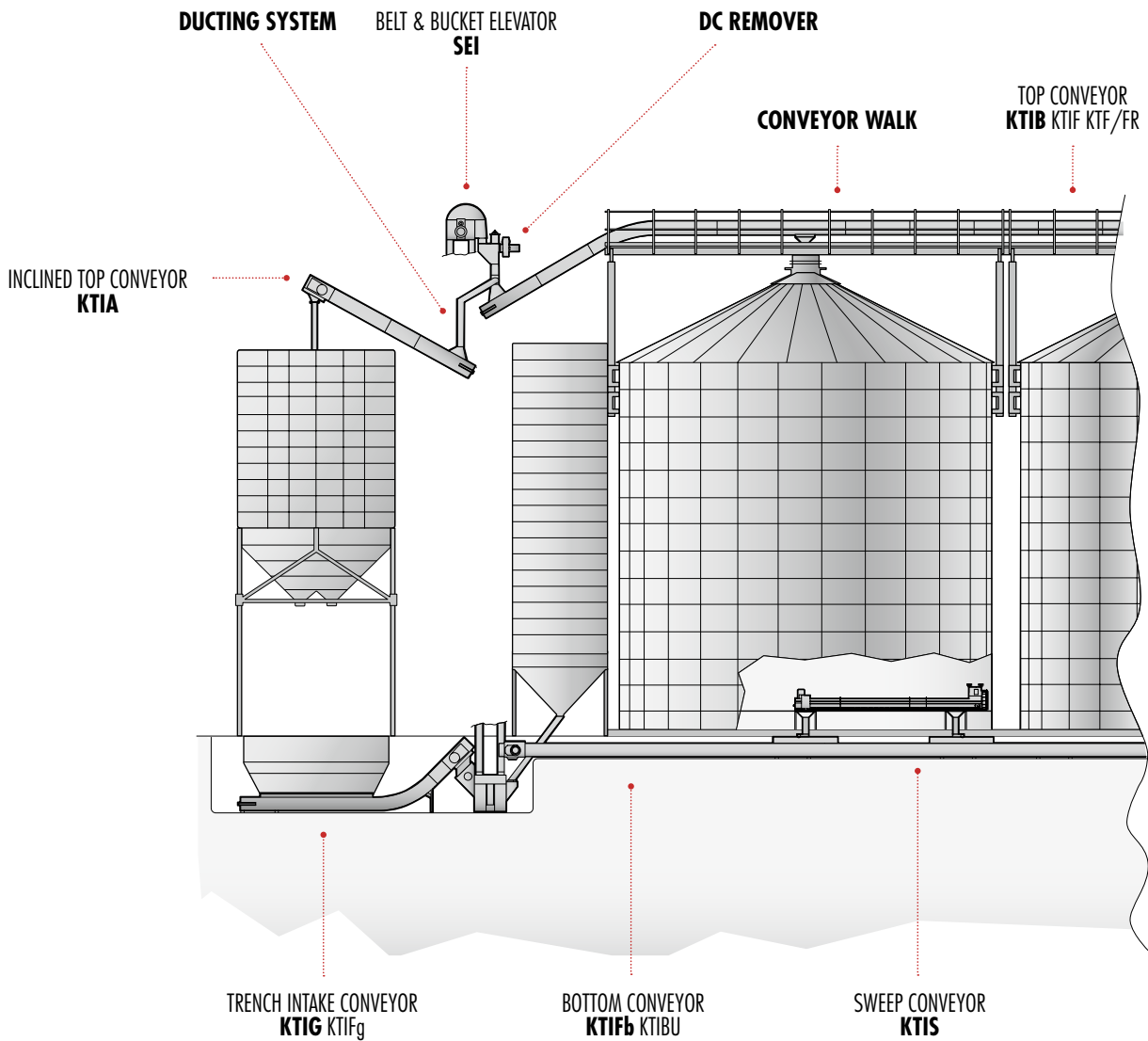

Our I-line products are designed for facilities running intensive operations all year round. Suitable for both medium-sized and large facilities.

CAPACITY



STORAGE SIZE

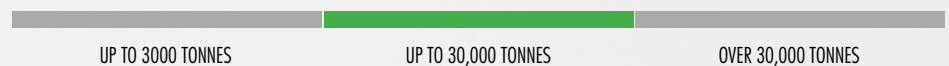

OPERATING TIME



PRODUCT LINE **H-LINE**

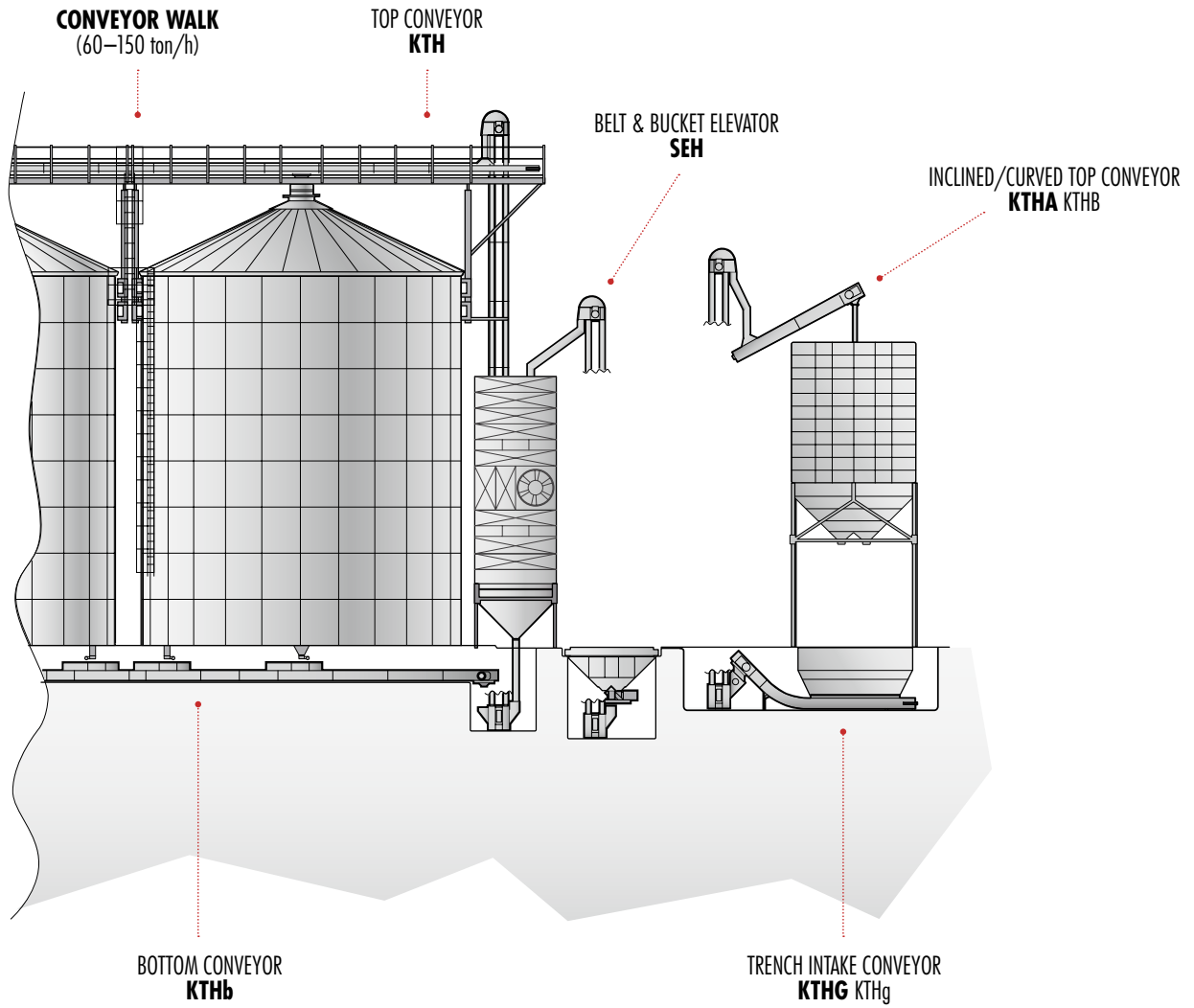

H-line has been developed to meet the stringent demands of industry in particular. Suitable for large facilities operating every day, all year round.

CAPACITY

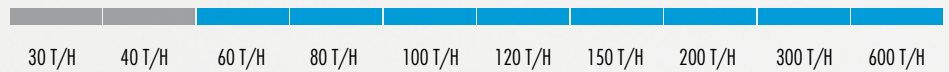

STORAGE SIZE



OPERATING TIME



PRODUCT ELEVATOR

ELEVATORS

A range of variants available for feeding and emptying with vertical conveying. We manufacture belt and bucket elevators and chain elevators at Skandia Elevator.

L-LINE

SE 140 TVM
KE 40

I-LINE

SEI 35/14
SEI 50/18
SEI 50/23

H-LINE

SEH 50/18
SEH 50/23
SEH 63/28
SEH 63/33
SEH 80/28
SEH 80/33

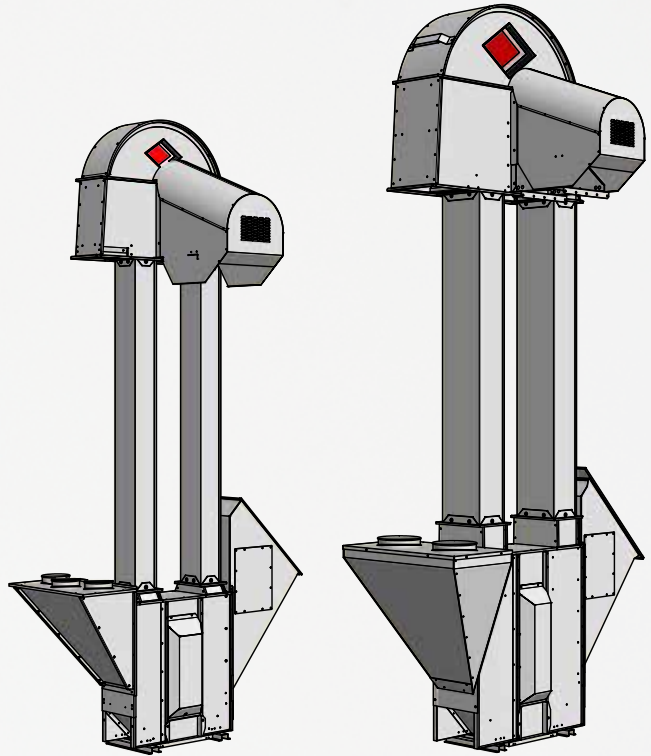

PRODUCT CONVEYOR

TRENCH INTAKE CONVEYORS

A trench intake conveyor is normally the first stage in a system and controls the capacity of the downstream conveying line.

L-LINE

KTG

I-LINE

KTIFg
KTIG

H-LINE

KTHg
KTHG

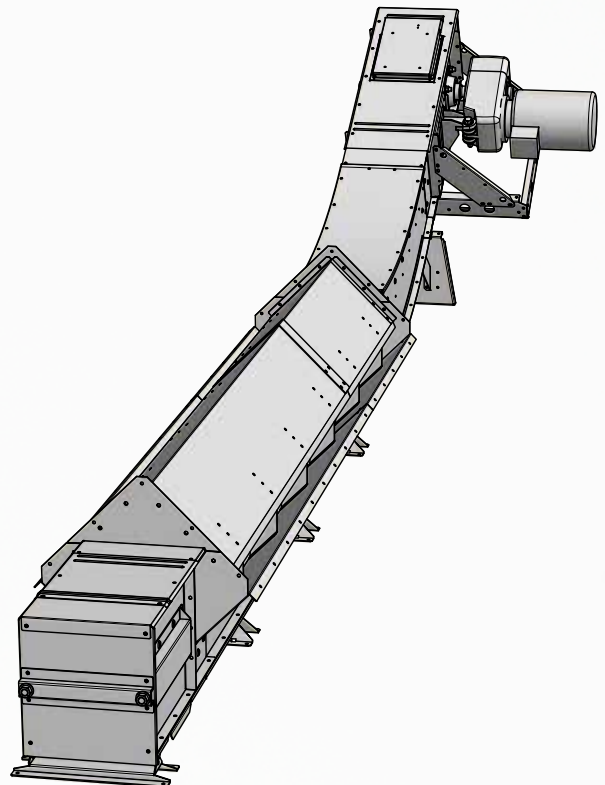

TOP CONVEYORS

The grain is fed from the system's elevator to a top conveyor. It is fully adapted to suit the capacity of the elevator in question.

L-LINE

KTF
KTF/R
KTA
KTB

I-LINE

KTIF
KTIF/FR
KTIA
KTIB

H-LINE

KTH
KTHA
KTHB

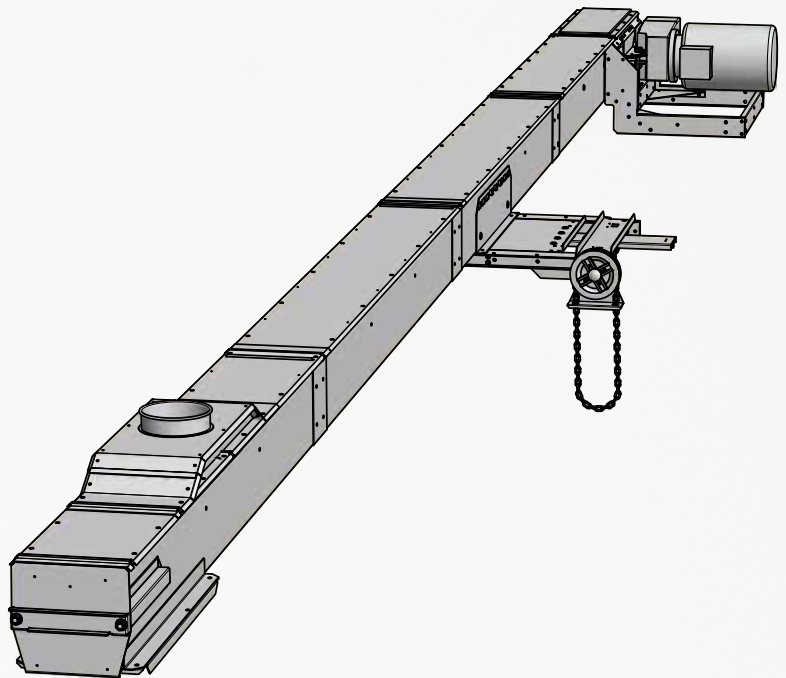

BOTTOM CONVEYORS

Our bottom conveyors are designed for efficient emptying of grain. For extra security, they are also fitted with inlets to prevent overfilling – a function that makes us quite unique in the market.

L-LINE

KTFb
KTAb
KTBU

I-LINE

KTIFb
KTIBU

H-LINE

KTHb
KTHBU

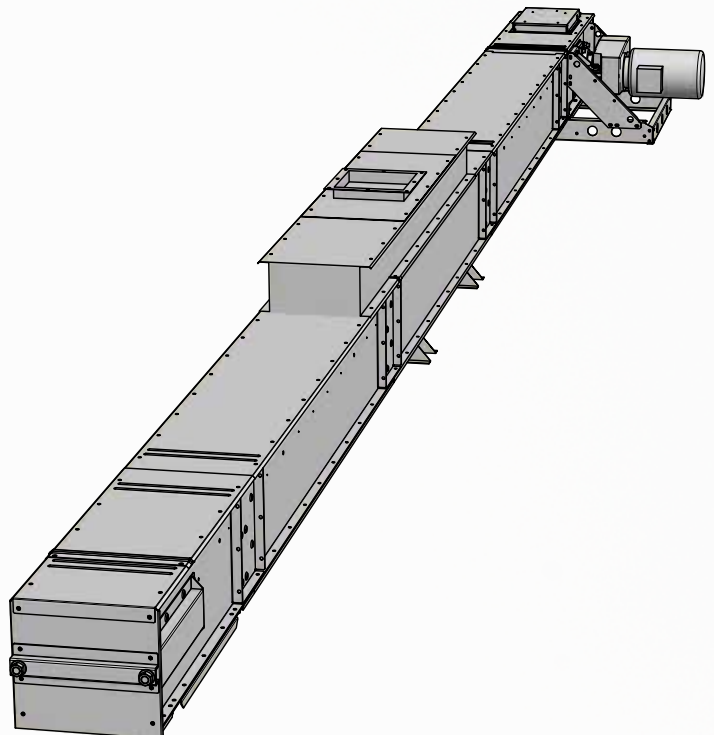

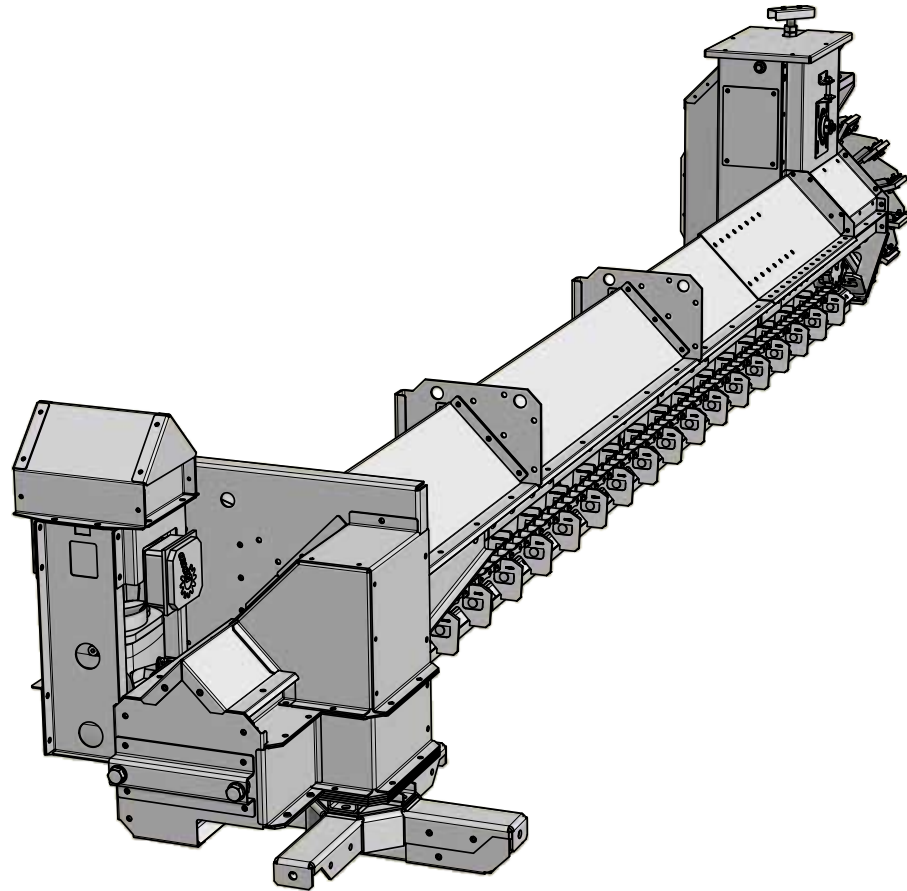

SWEEP CONVEYOR

The technology in our sweep conveyor consists of a chain with flights and longitudinal brooms that set a whole new standard in the industry in terms of cleanliness when it comes to emptying silos.

L-LINE



KTIS

I-LINE



KTIS

H-LINE



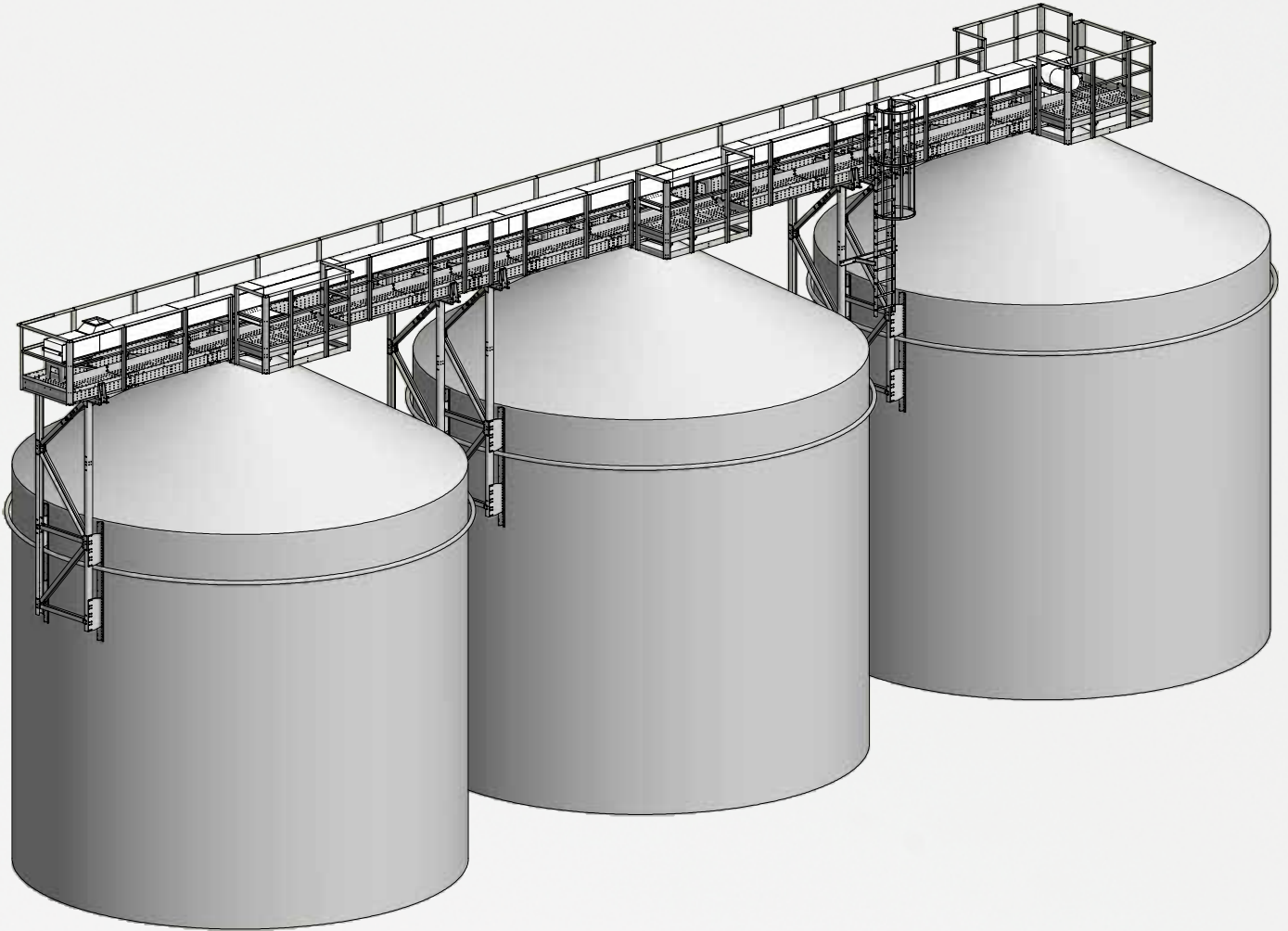

CONVEYOR WALK

Our conveyor walk provides easier access to the conveyor on top of the silo. The conveyor and conveyor walk are adapted to fit one another, which makes servicing and maintenance simple and straightforward.

L-LINE

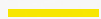

CONVEYOR WALK

I-LINE



CONVEYOR WALK

H-LINE



CONVEYOR WALK

DC REMOVER

The lines also include a dust and chaff extractor (DC Remover) that is designed for rough sorting of grain and to clean away dust, chaff and light straw.

L-LINE

DC REMOVER

I-LINE

DC REMOVER

H-LINE

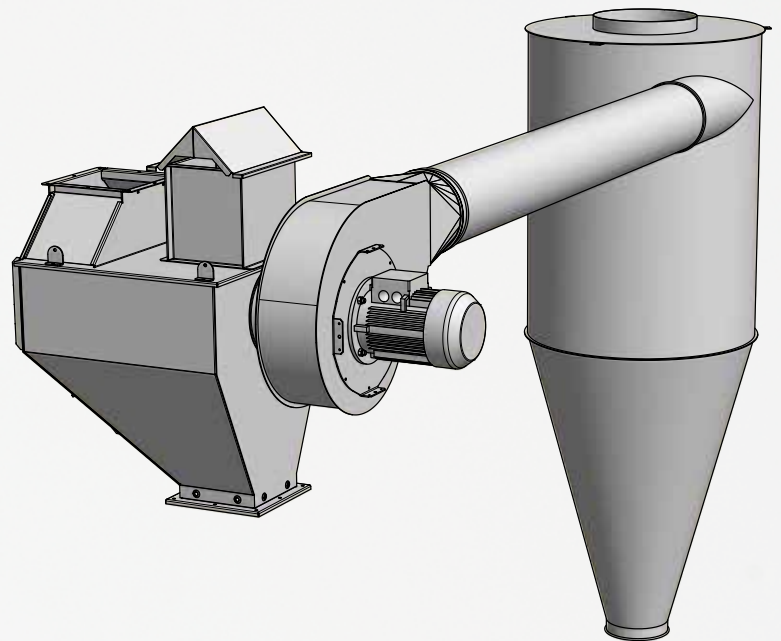

DUCTING SYSTEM

Skandia Elevator offers two different galvanised metal ducting systems. Pipes of a 1 mm material thickness are available in $\varnothing 160$, $\varnothing 200$ and $\varnothing 250$ mm. A material thickness of 2 mm is used for industrial purposes, and these are available in $\varnothing 200$, $\varnothing 250$ and $\varnothing 300$ mm. Both ranges include a broad selection of accessories such as 2, 3, 6 and 8-way valves.

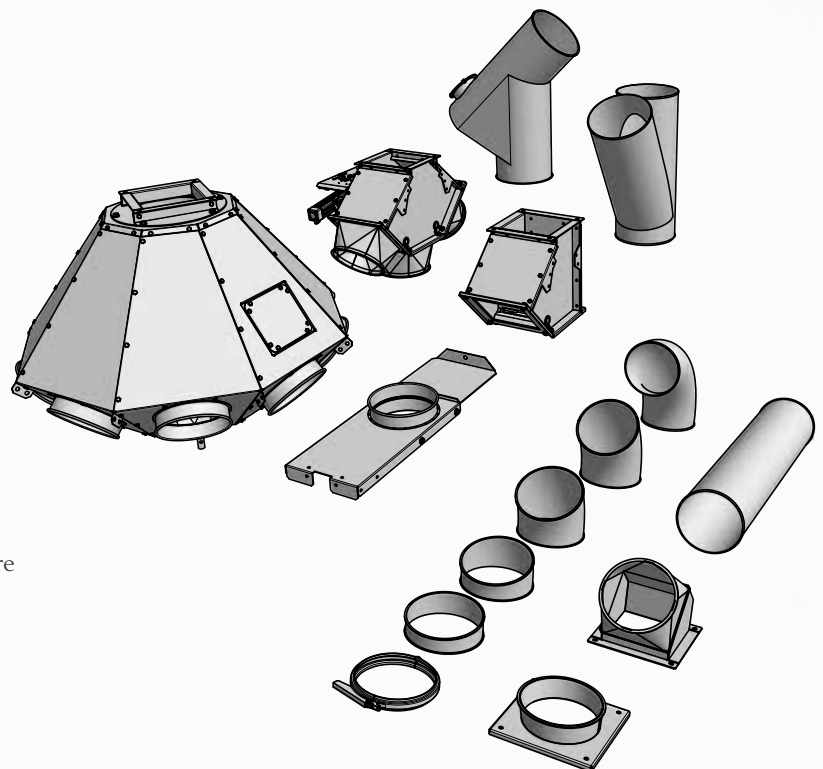



OUR QUALITY LABEL

You will see the label "Moving Parts from Skandia Elevator" on our systems. This is our quality hallmark, which indicates that the inside of the system and its moving parts are of the same high quality as the outside.

The moving parts are most critical elements in a system as they present the greatest risk of stoppages and breakdowns. At Skandia Elevator we know just how costly and stressful such disruptions are. We have invested a lot of time and energy in developing systems that minimise the risk of stoppages.





THE LEADING COMPANY





THE LEADING COMPANY

Being a leading company is about so much more than offering the best products on the market at competitive prices.

We bear responsibility for spearheading development in the industry, something we do by going our own way and constantly seeking innovative solutions for transporting grain. That said, we focus on our customers at all times and are receptive to your needs and wishes.



**SKANDIA
ELEVATOR**
THE LEADING COMPANY

Skandia Elevator, S-534 94 Vara, Sweden
Phone +46 512 797 000 E-mail info@skandiaelevator.com

WWW.SKANDIAELEVATOR.COM